

The leader of domestic motion control solution provider

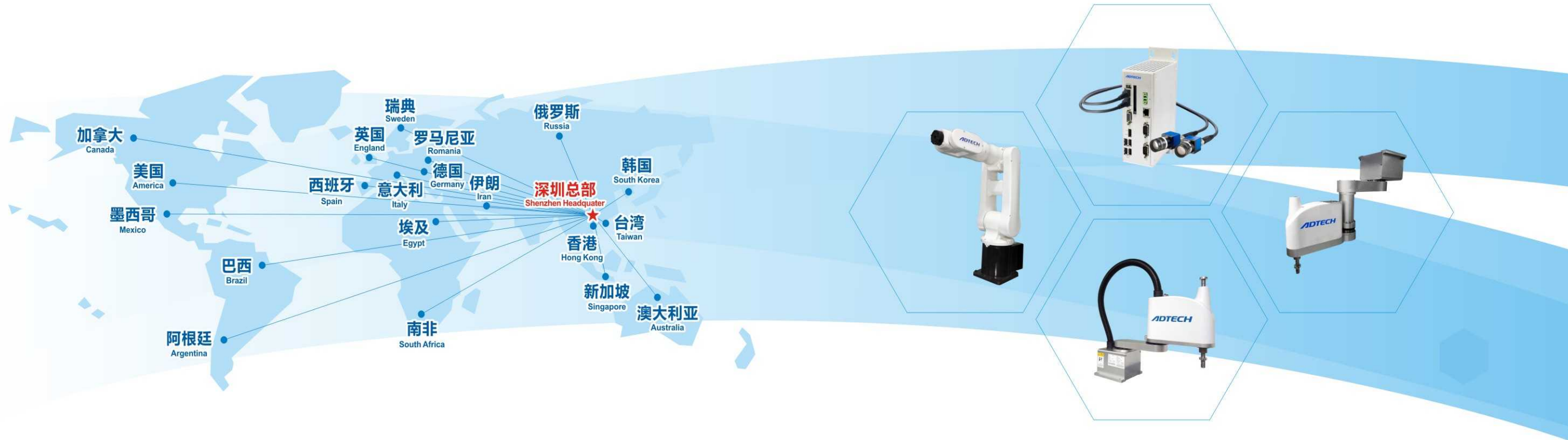

ADTECH (SHENZHEN) TECHNOLOGY CO., LTD.

Address: 5th Floor, Tianxia IC Industrial Park, Majialong, Yiyuan Road, Nanshan District, Shenzhen City, Guangdong Province, P.R.China

Tel : +86-755-2609 9116

Fax: +86-755-2672 2718

Mob: +86 139 0296 6285

Email: export@machine-controller.com

Website: www.machine-controller.com

www.adtechen.com

SCARA ROBOT

- SCARA ROBOT
- SIX-AXIS ROBOT
- ROBOT VISION SYSTEM





Catalog

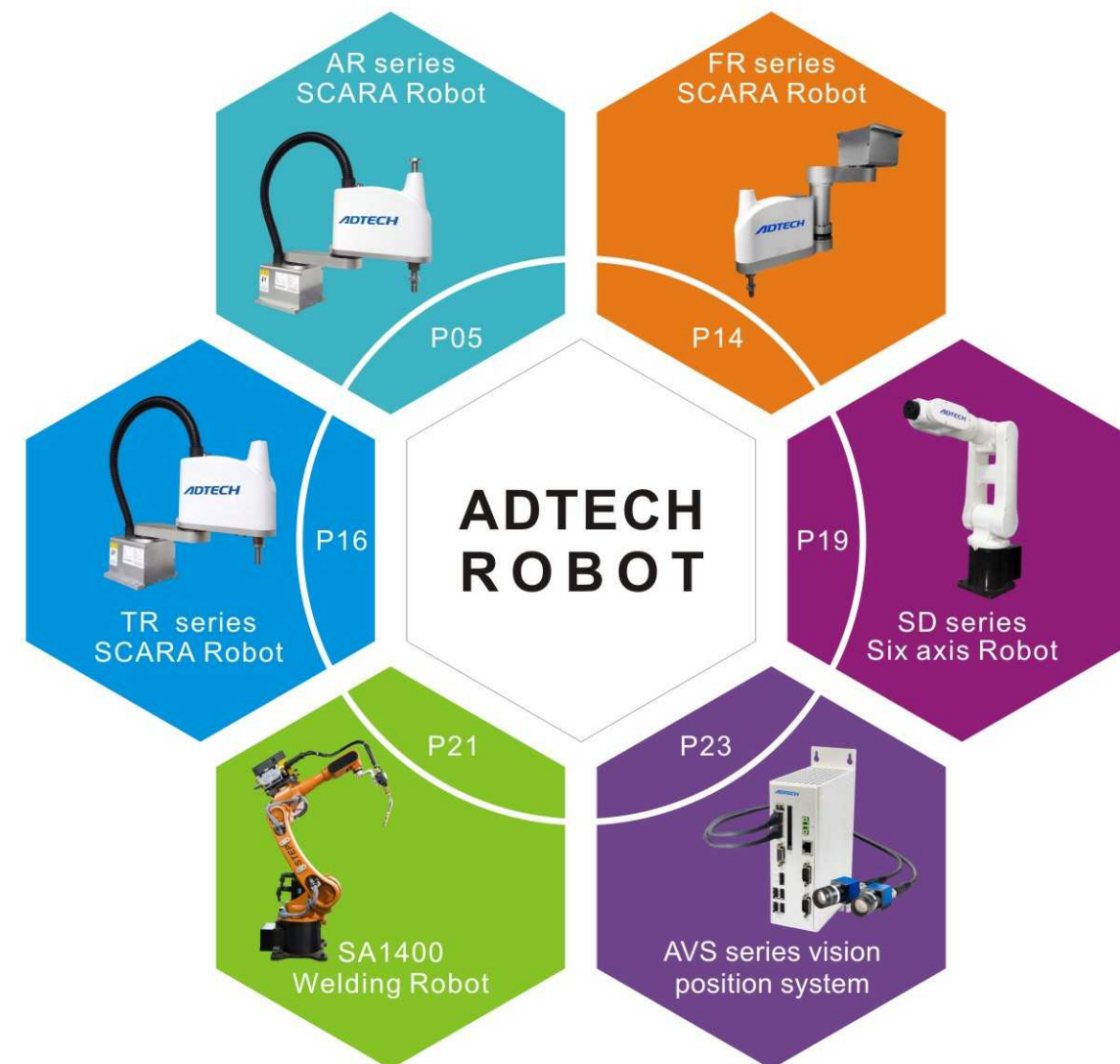

As China's leading motion control solution supplier, ADTECH establishes 2 product systems : motion control system (motion controller, stepper & servo driver, motor and industry application software) ; Industrial robot, widely used in machines, plastic industry, aerospace, medical instrument, electronic assemble, metal cutting, daily use chemical industry and so on, ADTECH is becoming a typical brand in motion control application area.

ADTECH has set up liaison office in 10 major cities in China, service center in more than 30 cities, building up global sales & service network, ADTECH products have been sold to 103 countries including Europe & America, the middle east, southeast Asia, Hongkong, Taiwan and so on.



ShenZhen Headquarter



Marketing Center











R&D department



Training centre



AR SERIES - four axis SCARA robot

Model		AR3215	AR4215	AR5215	AR6520	AR7520	AR8520	AR61030	AR7225	AR101030	
Diagram											
Species		SCARA	SCARA	SCARA	SCARA	SCARA	SCARA	SCARA	SCARA	SCARA	
Number of axes		4	4	4	4	4	4	4	4	4	
Arm length		300mm	400mm	500mm	600mm	700mm	800mm	600mm	700mm	1000mm	
Axis specification	X axis	Arm length	100mm	200mm	300mm	300mm	400mm	500mm	200mm	400mm	600mm
		Rotation range	±127°	±127°	±127°	±130°	±130°	±130°	±135°	±130°	±135°
	Y axis	Arm length	200mm	200mm	200mm	300mm	300mm	300mm	400mm	300mm	400mm
		Rotation range	±142°	±142°	±142°	±140°	±140°	±140°	±150°	±140°	±150°
	Z axis	Route	150mm	150mm	150mm	200mm	200mm	200mm	300mm	250mm	300mm
R axis	Rotation range	±360°	±360°	±360°	±360°	±360°	±360°	±360°	±360°	±360°	
Highest speed	X axis	600°/s	600°/s	600°/s	375°/s	300°/s	250°/s	375°/s	375°/s	337.5°/s	
	Y axis	600°/s	600°/s	600°/s	600°/s	600°/s	600°/s	375°/s	600°/s	375°/s	
	X, Y-axis synthesis	5.2m/s	6.3m/s	7.3m/s	7.1m/s	6.8m/s	6.6m/s	6.5m/s	7.7m/s	8.5m/s	
	Z axis	1.3m/s	1.3m/s	1.3m/s	1.1m/s	1.1m/s	1.1m/s	1.4m/s	1.21m/s	1.4m/s	
	R axis	1667°/s	1667°/s	1667°/s	1500°/s	1500°/s	1500°/s	1000°/s	1500°/s	1000°/s	
Standard Cycle Time		0.5s	0.4s	0.48s	0.43s	0.42s	0.4s	0.53s	0.37s	1s	
Repeat positioning accuracy	X, Y-axis	±0.01mm	±0.01mm	±0.01mm	±0.015mm	±0.015mm	±0.015mm	±0.03mm	±0.015mm	±0.03mm	
	Z axis	±0.01mm	±0.01mm	±0.01mm	±0.01mm	±0.01mm	±0.01mm	±0.015mm	±0.01mm	±0.02mm	
	R axis	±0.005°	±0.005°	±0.005°	±0.005°	±0.005°	±0.005°	±0.005°	±0.005°	±0.01°	
Rated / max load		2kg/5kg	2kg/5kg	2kg/5kg	5kg/10kg	5kg/10kg	5kg/10kg	10kg/20kg	2kg/5kg	10kg/20kg	
R axis allows load moment of inertia (Rated / max)		0.005 kg·m ²	0.005 kg·m ²	0.005 kg·m ²	0.05 kg·m ²	0.05 kg·m ²	0.05 kg·m ²	0.5kg·m ²	0.005 kg·m ²	0.1 kg·m ²	
		0.035kg·m ²	0.035 kg·m ²	0.035 kg·m ²	0.2 kg·m ²	0.2 kg·m ²	0.2 kg·m ²	1 kg·m ²	0.035 kg·m ²	0.5 kg·m ²	
User signal line		0.2sq × 16 lines, 8 output, 6 input	0.2sq × 16 lines, 8 output, 6 input	0.2sq × 16 lines, 8 output, 6 input	0.2sq × 16 lines, 8 output, 6 input	0.2sq × 16 lines, 8 output, 6 input	0.2sq × 16 lines, 8 output, 6 input	0.2sq × 16 lines, 8 output, 6 input	0.2sq × 16 lines, 8 output, 6 input	0.2sq × 16 lines, 8 output, 6 input	
Users pipe		Φ6×2 root	Φ6×2 root	Φ6×2 root	Φ6×2 root	Φ6×2 root	Φ6×2 root	Φ6×2 root	Φ6×2 root	Φ6×2 root	
Limit protection		1. Software limit 2. Mechanical limit (X, Y, Z axis)	1. Software limit 2. Mechanical limit (X, Y, Z axis)	1. Software limit 2. Mechanical limit (X, Y, Z axis)	1. Software limit 2. Mechanical limit (X, Y, Z axis)	1. Software limit 2. Mechanical limit (X, Y, Z axis)	1. Software limit 2. Mechanical limit (X, Y, Z axis)	1. Software limit 2. Mechanical limit (X, Y, Z axis)	1. Software limit 2. Mechanical limit (X, Y, Z axis)	1. Software limit 2. Mechanical limit (X, Y, Z axis)	
Weight		13.1kg	13.3kg	13.6kg	24.3kg	25kg	26.5kg	32.8kg	20.7kg	39.26kg	

FR SERIES - four axis hanging type SCARA robot

Model		FR5215	FR6115	
Diagram				
Species		SCARA	SCARA	
Number of axes		4	4	
Arm length		550mm	600mm	
Axis specification	X axis	Arm length	250mm	300mm
		Rotation range	±360°	±360°
	Y axis	Arm length	300mm	300mm
		Rotation range	±360°	±360°
	Z axis	Route	150mm	150mm
R axis	Rotation range	±360°	±360°	
Highest speed	X axis	517.6°/s	517.6°/s	
	Y axis	374.3°/s	374.3°/s	
	X, Y-axis synthesis	6.9m/s	7.4m/s	
	Z axis	1.3m/s	1.3m/s	
	R axis	1666.7°/s	1666.7°/s	
Standard Cycle Time		0.42s	0.38s	
Repeat positioning accuracy	X, Y-axis	±0.025mm	±0.025mm	
	Z axis	±0.01mm	±0.01mm	
	R axis	±0.005°	±0.005°	
Rated / max load		2kg/5kg	1kg/3kg	
R axis allows load moment of inertia (Rated / max)		0.005 kg·m ²	0.005 kg·m ²	
		0.035 kg·m ²	0.035 kg·m ²	
User signal line		0.2sq × 16 lines, 8 output, 6 input	0.2sq × 16 lines, 8 output, 6 input	
Users pipe		Φ4×2 root	Φ4×2 root	
Limit protection		Software limit	Software limit	
Weight		21kg	21.5kg	

TR SERIES - three axis SCARA robot

Model		TR3208	TR4208	TR5208	
Diagram					
Species		SCARA	SCARA	SCARA	
Number of axes		3	3	3	
Arm length		300mm	400mm	500mm	
Axis specification	X axis	Arm length	100mm	200mm	300mm
		Rotation range	±127°	±127°	±127°
	Y axis	Arm length	200mm	200mm	200mm
		Rotation range	±142°	±142°	±142°
Z axis	Route	80mm	80mm	80mm	
Highest speed	X axis	600°/s	600°/s	600°/s	
	Y axis	375°/s	375°/s	375°/s	
	X, Y-axis synthesis	4.45m/s	5.5m/s	6.5m/s	
	Z axis	0.83m/s	0.83m/s	0.83m/s	
Standard Cycle Time		0.45s	0.4s	0.45s	
Repeat positioning accuracy	X, Y-axis	±0.01mm	±0.01mm	±0.01mm	
	Z axis	±0.01mm	±0.01mm	±0.01mm	
R axis allows load moment of inertia (Rated / max)		2kg/5kg	2kg/5kg	2kg/5kg	
User signal line		0.2sq × 16 lines, 8 output, 6 input	0.2sq × 16 lines, 8 output, 6 input	0.2sq × 16 lines, 8 output, 6 input	
Users pipe		Φ6×2 root	Φ6×2 root	Φ6×2 root	
Limit protection		1. Software limit 2. Mechanical limit (X, Y, Z axis)	1. Software limit 2. Mechanical limit (X, Y, Z axis)	1. Software limit 2. Mechanical limit (X, Y, Z axis)	
Weight		11.5kg	11.8kg	12.1kg	

SD series six axis robot

Model		SD500	SD700
Diagram			
Species		Vertical multi-joint	Vertical multi-joint
Number of axes		6	6
Arm length		500mm	700mm
Range of motion	J1	±170°	±170°
	J2	±115°	±115°
	J3	+40°~-220°	+40°~-220°
	J4	±185°	±185°
	J5	±125°	±125°
	J6	±360°	±360°
Maximum speed	J1	375°/s	250°/s
	J2	375°/s	185°/s
	J3	430°/s	290°/s
	J4	460°/s	460°/s
	J5	460°/s	460°/s
	J6	600°/s	600°/s
Repeat positioning accuracy		±0.02mm	±0.03mm
Wrist load	Rated	3kg	3kg
	Maximum	5kg	5kg
Maximum allowable instantaneous torque	J5	35Nm	35Nm
	J6	24Nm	24Nm
User signal line		0.14sqX16 lines	0.14sqX16 lines
Users pipe		Φ4×4 root	Φ4×4 root
Installation		Loading, flip, side	Loading, flip, side
Limit protection		1. Software limit 2. Mechanical limit	1. Software limit 2. Mechanical limit
Weight		26Kg	28Kg

ADTECH robot naming rules

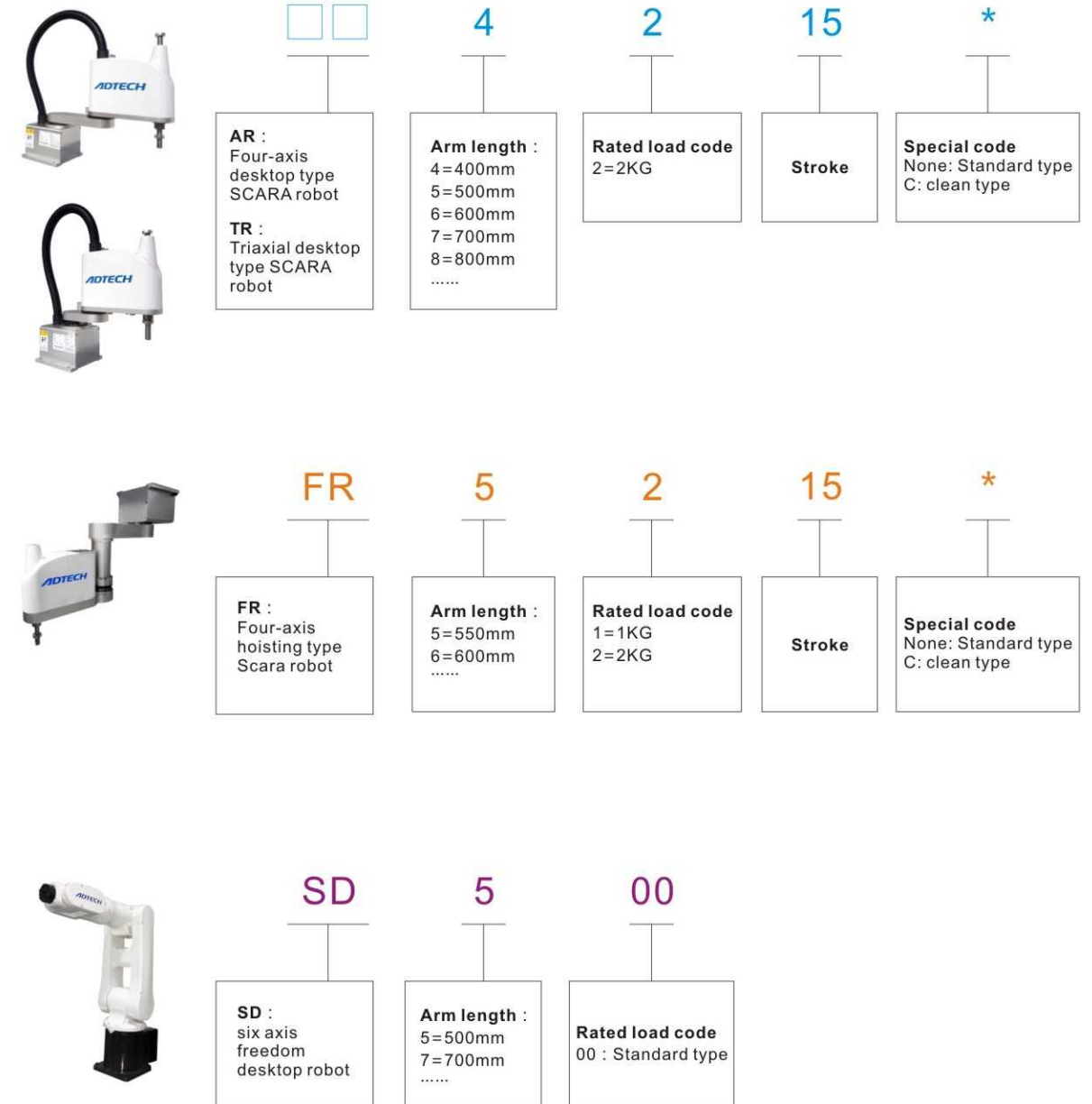

AR SERIES - four axis SCARA robot AR3215

■ Specification Table

Species		SCARA	
Axis specification	X axis	Arm length	100mm
		Rotation range	±127°
	Y axis	Arm length	200mm
		Rotation range	±142°
Z axis	Route	150mm	
R axis	Rotation range	±360°	
Highest speed	X axis	600°/s	
	Y axis	600°/s	
	X, Y-axis synthesis	5.2m/s	
	Z axis	1.3m/s	
	R axis	1667°/s	
Repeat positioning accuracy	X, Y-axis	±0.01mm	
	Z axis	±0.01mm	
	R axis	±0.005°	
R axis allows load moment of inertia (Rated / max)		0.005 kg·m ²	
		0.035 kg·m ²	
User signal line	1. Software limit 2. Mechanical limit (X, Y, Z axis)		
Users pipe	0.2sq × 16 lines, 8 output, 6 input		
Limit protection	Φ6×2 root		
Weight	13.1kg		



Standard Cycle Time

Standard cycle time (rated load)

0.5s

Arm length (mm)

300

Rated / max load

2kg/5kg

System



QC400A

■ Robot Movement Space, Shape and Installation Dimension (Unit: mm)

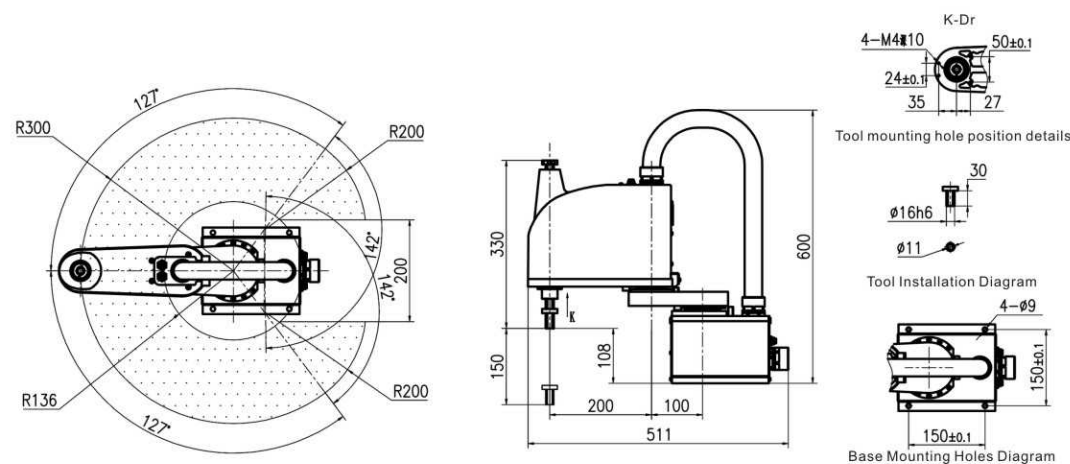

05

AR SERIES - four axis SCARA robot AR4215

■ Specification Table

Species		SCARA	
Axis specification	X axis	Arm length	200mm
		Rotation range	±127°
	Y axis	Arm length	200mm
		Rotation range	±142°
Z axis	Route	150mm	
R axis	Rotation range	±360°	
Highest speed	X axis	600°/s	
	Y axis	600°/s	
	X, Y-axis synthesis	6.3m/s	
	Z axis	1.3m/s	
	R axis	1667°/s	
Repeat positioning accuracy	X, Y-axis	±0.01mm	
	Z axis	±0.01mm	
	R axis	±0.005°	
R axis allows load moment of inertia (Rated / max)		0.005 kg·m ²	
		0.035 kg·m ²	
User signal line	1. Software limit 2. Mechanical limit (X, Y, Z axis)		
Users pipe	0.2sq × 16 lines, 8 output, 6 input		
Limit protection	Φ6×2 root		
Weight	13.3kg		



Standard Cycle Time

Standard cycle time (rated load)

0.4s

Arm length (mm)

400

Rated / max load

2kg/5kg

System



QC400A

■ Robot Movement Space, Shape and Installation Dimension (Unit: mm)

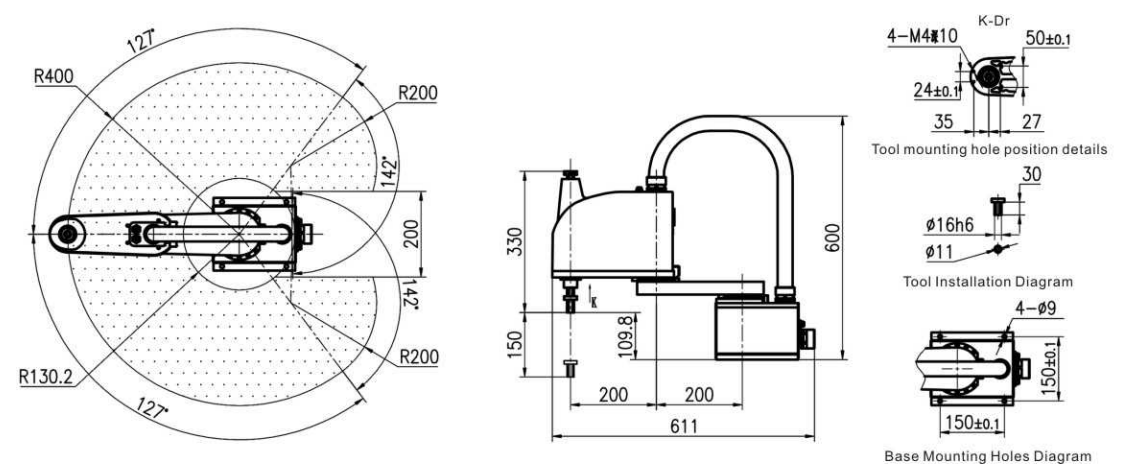

06

AR SERIES - four axis SCARA robot

AR5215

■ Specification Table

Species		SCARA	
Axis specification	X axis	Arm length	300mm
		Rotation range	±127°
	Y axis	Arm length	200mm
		Rotation range	±142°
	Z axis	Route	150mm
R axis	Rotation range	±360°	
Highest speed	X axis	600°/s	
	Y axis	600°/s	
	X, Y-axis synthesis	7.3m/s	
	Z axis	1.3m/s	
	R axis	1667°/s	
Repeat positioning accuracy	X, Y-axis	±0.01mm	
	Z axis	±0.01mm	
	R axis	±0.005°	
R axis allows load moment of inertia (Rated / max)		0.005 kg·m ²	
		0.035 kg·m ²	
User signal line	1. Software limit 2. Mechanical limit (X, Y, Z axis)		
Users pipe	0.2sq × 16 lines, 8 output, 6 input		
Limit protection	Φ6×2 root		
Weight	13.6kg		



Standard cycle time (rated load)

0.48s

Arm length (mm)

500

Rated / max load

2kg/5kg

System

QC400A

■ Robot Movement Space, Shape and Installation Dimension (Unit: mm)

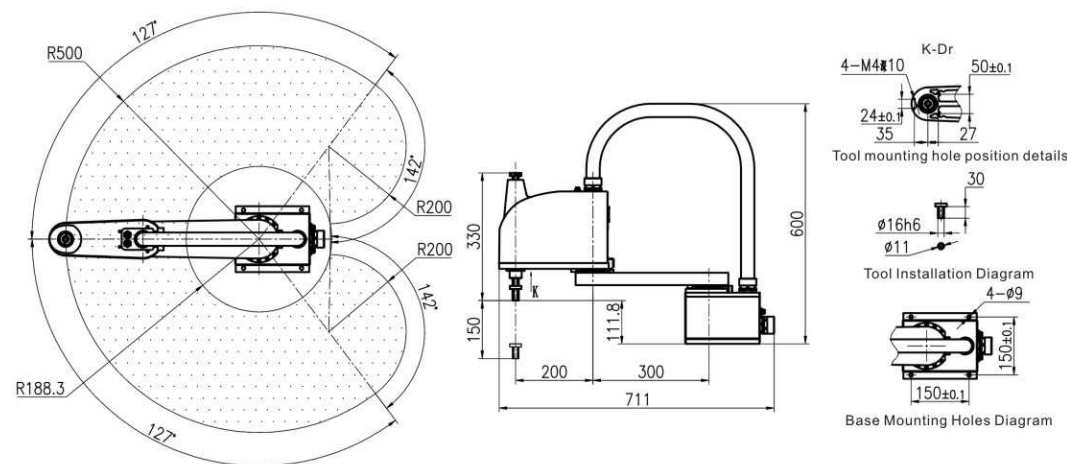

AR SERIES - four axis SCARA robot

AR6520

■ Specification Table

Species		SCARA	
Axis specification	X axis	Arm length	300mm
		Rotation range	±130°
	Y axis	Arm length	300mm
		Rotation range	±140°
	Z axis	Route	200mm
R axis	Rotation range	±360°	
Highest speed	X axis	375°/s	
	Y axis	600°/s	
	X, Y-axis synthesis	7.1m/s	
	Z axis	1.1m/s	
	R axis	1500°/s	
Repeat positioning accuracy	X, Y-axis	±0.015mm	
	Z axis	±0.01mm	
	R axis	±0.005°	
R axis allows load moment of inertia (Rated / max)		0.05 kg·m ²	
		0.2 kg·m ²	
User signal line	1. Software limit 2. Mechanical limit (X, Y, Z axis)		
Users pipe	0.2sq × 16 lines, 8 output, 6 input		
Limit protection	Φ6×2 root		
Weight	24.3kg		



Standard cycle time (rated load)

0.43s

Arm length (mm)

600

Rated / max load

5kg/10kg

System

QC400A

■ Robot Movement Space, Shape and Installation Dimension (Unit: mm)

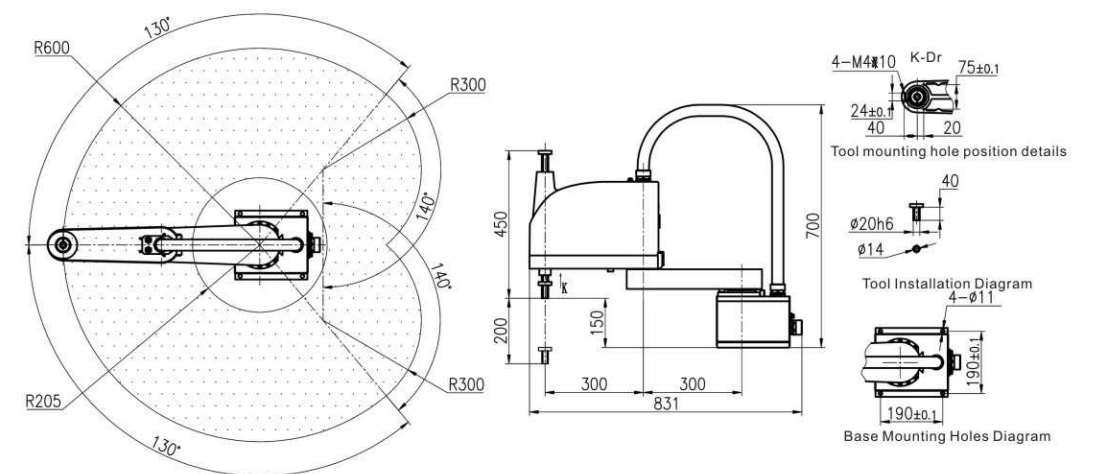

AR SERIES - four axis SCARA robot

AR7520

■ Specification Table

Species		SCARA	
Axis specification	X axis	Arm length	400mm
		Rotation range	±130°
	Y axis	Arm length	300mm
		Rotation range	±140°
Z axis	Route	200mm	
R axis	Rotation range	±360°	
Highest speed	X axis	300°/s	
	Y axis	600°/s	
	X, Y-axis synthesis	6.8m/s	
	Z axis	1.1m/s	
	R axis	1500°/s	
Repeat positioning accuracy	X, Y-axis	±0.015mm	
	Z axis	±0.01mm	
	R axis	±0.005°	
R axis allows load moment of inertia (Rated / max)		0.05 kg·m ²	
		0.2 kg·m ²	
User signal line	1. Software limit 2. Mechanical limit (X, Y, Z axis)		
Users pipe	0.2sq × 16 lines, 8 output, 6 input		
Limit protection	Φ6×2 root		
Weight	25kg		



Standard cycle time (rated load) **0.42s**

Arm length (mm) **700**

Rated / max load **5kg/10kg**



AR SERIES - four axis SCARA robot

AR8520

■ Specification Table

Species		SCARA	
Axis specification	X axis	Arm length	500mm
		Rotation range	±130°
	Y axis	Arm length	300mm
		Rotation range	±140°
Z axis	Route	200mm	
R axis	Rotation range	±360°	
Highest speed	X axis	250°/s	
	Y axis	600°/s	
	X, Y-axis synthesis	6.6m/s	
	Z axis	1.1m/s	
	R axis	1500°/s	
Repeat positioning accuracy	X, Y-axis	±0.015mm	
	Z axis	±0.01mm	
	R axis	±0.005°	
R axis allows load moment of inertia (Rated / max)		0.05 kg·m ²	
		0.2 kg·m ²	
User signal line	1. Software limit 2. Mechanical limit (X, Y, Z axis)		
Users pipe	0.2sq × 16 lines, 8 output, 6 input		
Limit protection	Φ6×2 root		
Weight	26.5kg		



Standard cycle time (rated load) **0.4s**

Arm length (mm) **800**

Rated / max load **5kg/10kg**



■ Robot Movement Space, Shape and Installation Dimension (Unit: mm)

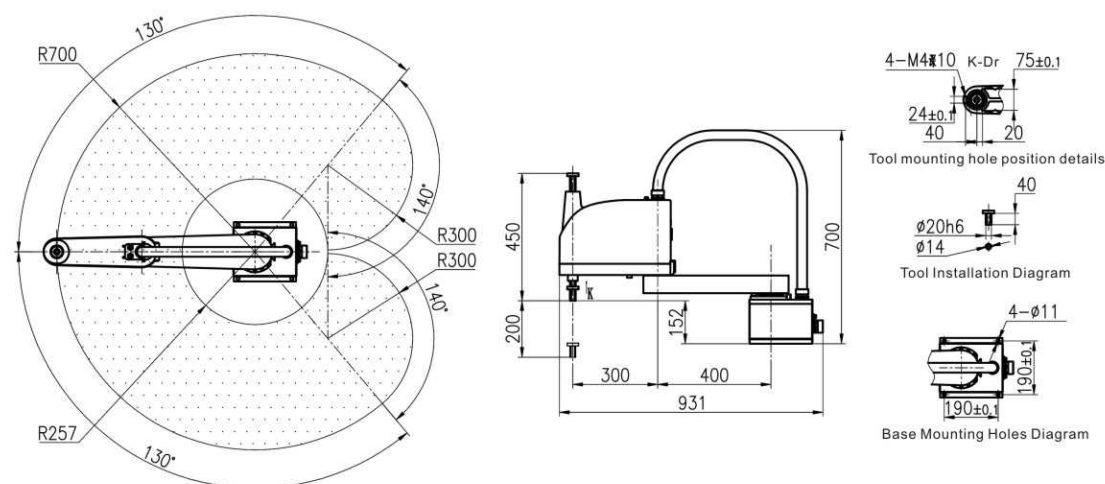

■ Robot Movement Space, Shape and Installation Dimension (Unit: mm)

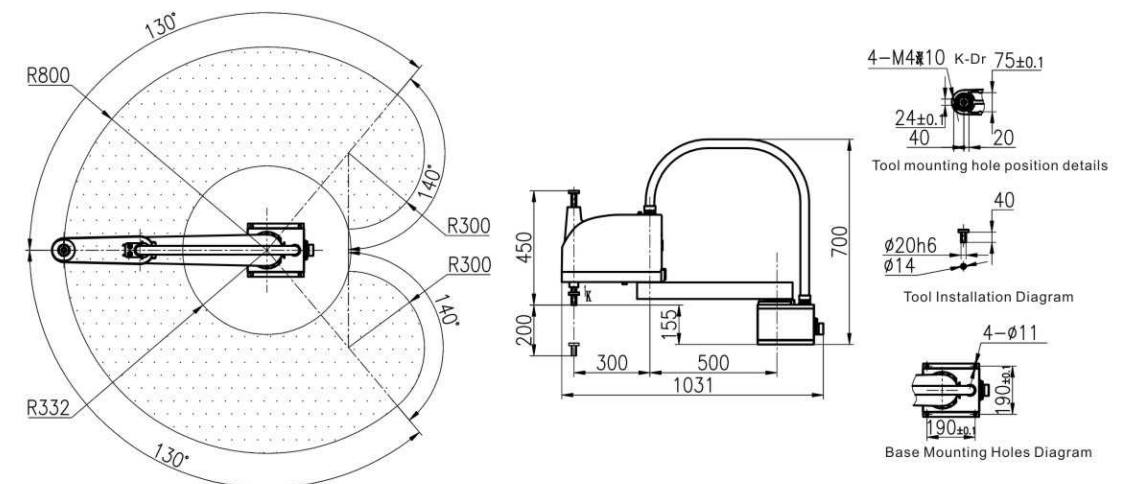

AR SERIES - four axis SCARA robot

AR61030

Specification Table

Species		SCARA	
Axis specification	X axis	Arm length	200mm
		Rotation range	±135°
	Y axis	Arm length	400mm
		Rotation range	±150°
Z axis	Route	300mm	
R axis	Rotation range	±360°	
Highest speed	X axis	375°/s	
	Y axis	375°/s	
	X, Y-axis synthesis	6.5m/s	
	Z axis	1.4m/s	
R axis	1000°/s		
Repeat positioning accuracy	X, Y-axis	±0.03mm	
	Z axis	±0.015mm	
	R axis	±0.005°	
R axis allows load moment of inertia (Rated / max)		0.5kg·m ²	
		1 kg·m ²	
User signal line	1. Software limit 2. Mechanical limit (X, Y, Z axis)		
Users pipe	0.2sq × 16 lines, 8 output, 6 input		
Limit protection	Φ6×2 root		
Weight	32.8kg		



Standard cycle time (rated load) **0.53s**

Arm length (mm) **600**

Rated / max load **10kg/20kg**



AR SERIES - four axis SCARA robot

AR7225

Specification Table

Species		SCARA	
Axis specification	X axis	Arm length	400mm
		Rotation range	±130°
	Y axis	Arm length	300mm
		Rotation range	±140°
Z axis	Route	250mm	
R axis	Rotation range	±360°	
Highest speed	X axis	375°/s	
	Y axis	600°/s	
	X, Y-axis synthesis	7.7m/s	
	Z axis	1.21m/s	
R axis	1500°/s		
Repeat positioning accuracy	X, Y-axis	±0.015mm	
	Z axis	±0.01mm	
	R axis	±0.005°	
R axis allows load moment of inertia (Rated / max)		0.005 kg·m ²	
		0.035 kg·m ²	
User signal line	1. Software limit 2. Mechanical limit (X, Y, Z axis)		
Users pipe	0.2sq × 16 lines, 8 output, 6 input		
Limit protection	Φ6×2 root		
Weight	20.7kg		



Standard cycle time (rated load) **0.37s**

Arm length (mm) **700**

Rated / max load **2kg/5kg**



Robot Movement Space, Shape and Installation Dimension (Unit: mm)

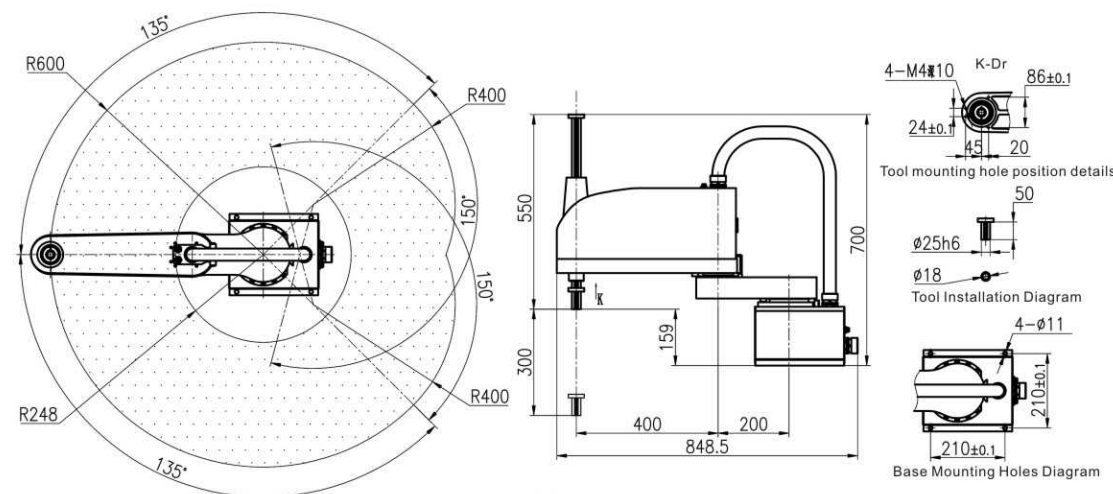

Robot Movement Space, Shape and Installation Dimension (Unit: mm)

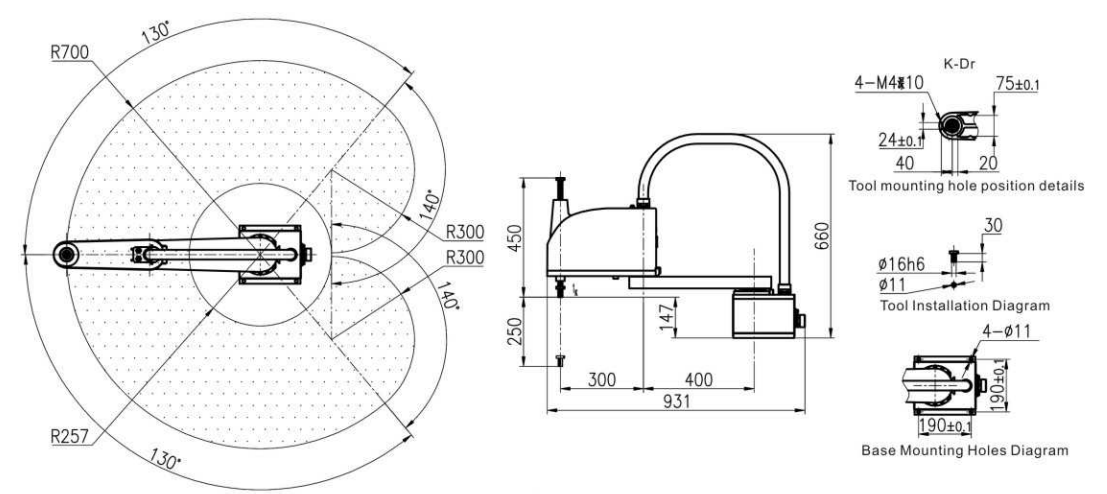

AR SERIES - four axis SCARA robot

AR101030

■ Specification Table

Species		SCARA	
Axis specification	X axis	Arm length	600mm
		Rotation range	±135°
	Y axis	Arm length	400mm
		Rotation range	±150°
Z axis	Route	300mm	
R axis	Rotation range	±360°	
Highest speed	X axis	337.5°/s	
	Y axis	375°/s	
	X, Y-axis synthesis	8.5m/s	
	Z axis	1.4m/s	
R axis	1000°/s		
Repeat positioning accuracy	X, Y-axis	±0.03mm	
	Z axis	±0.02mm	
	R axis	±0.01°	
R axis allows load moment of inertia (Rated / max)		0.1kg·m ²	
		0.5kg·m ²	
User signal line	1. Software limit 2. Mechanical limit (X, Y, Z axis)		
Users pipe	0.2sq × 16 lines, 8 output, 6 input		
Limit protection	Φ6×2 root		
Weight	39.26kg		



Standard cycle time (rated load)

1s

Arm length (mm)

1000

Rated / max load

10kg/20kg

System

QC400A

■ Robot Movement Space, Shape and Installation Dimension (Unit: mm)

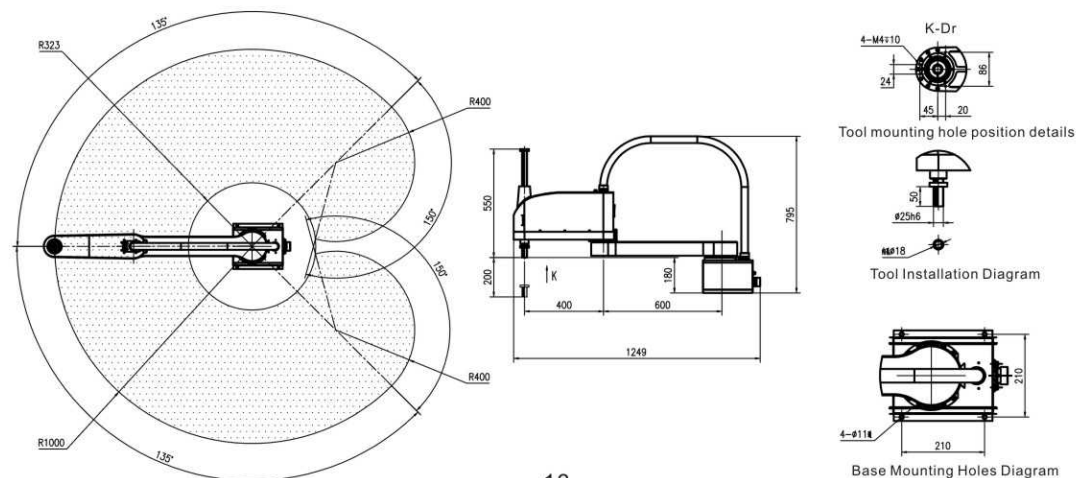

FR SERIES - four axis hanging type SCARA robot

FR5215

■ Specification Table

Species		SCARA	
Axis specification	X axis	Arm length	250mm
		Rotation range	±360°
	Y axis	Arm length	300mm
		Rotation range	±360°
Z axis	Route	150mm	
R axis	Rotation range	±360°	
Highest speed	X axis	517.6°/s	
	Y axis	374.3°/s	
	X, Y-axis synthesis	6.9m/s	
	Z axis	1.3m/s	
R axis	1666.7°/s		
Repeat positioning accuracy	X, Y-axis	±0.025mm	
	Z axis	±0.01mm	
	R axis	±0.005°	
R axis allows load moment of inertia (Rated / max)		0.005 kg·m ²	
		0.035 kg·m ²	
User signal line	Software limit		
Users pipe	0.2sq × 16 lines, 8 output, 6 input		
Limit protection	Φ4×2 root		
Weight	21kg		



Standard cycle time (rated load)

0.42s

Arm length (mm)

550

Rated / max load

2kg/5kg

System

QC400A

■ Robot Movement Space, Shape and Installation Dimension (Unit: mm)

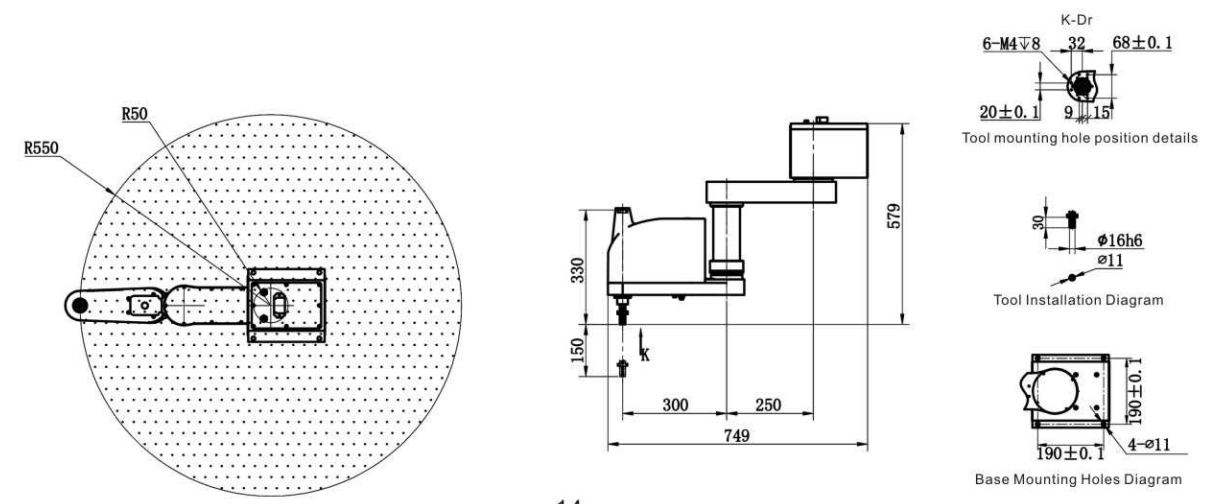

FR SERIES - four axis hanging type SCARA robot

FR6115

■ Specification Table

Species			SCARA
Axis specification	X axis	Arm length	300mm
		Rotation range	±360°
	Y axis	Arm length	300mm
		Rotation range	±360°
	Z axis	Route	150mm
R axis	Rotation range	±360°	
Highest speed	X axis		517.6°/s
	Y axis		374.3°/s
	X, Y-axis synthesis		7.4m/s
	Z axis		1.3m/s
	R axis		1666.7°/s
Repeat positioning accuracy	X, Y-axis		±0.025mm
	Z axis		±0.01mm
	R axis		±0.005°
R axis allows load moment of inertia (Rated / max)			0.005 kg·m ² 0.035 kg·m ²
User signal line			Software limit
Users pipe			0.2sq × 16 lines, 8 output, 6 input
Limit protection			Φ6×2 root
Weight			21.5kg



Standard cycle time (rated load)

0.38s

Arm length (mm)

600

Rated / max load

1kg/3kg

System

QC400A

■ Robot Movement Space, Shape and Installation Dimension (Unit: mm)

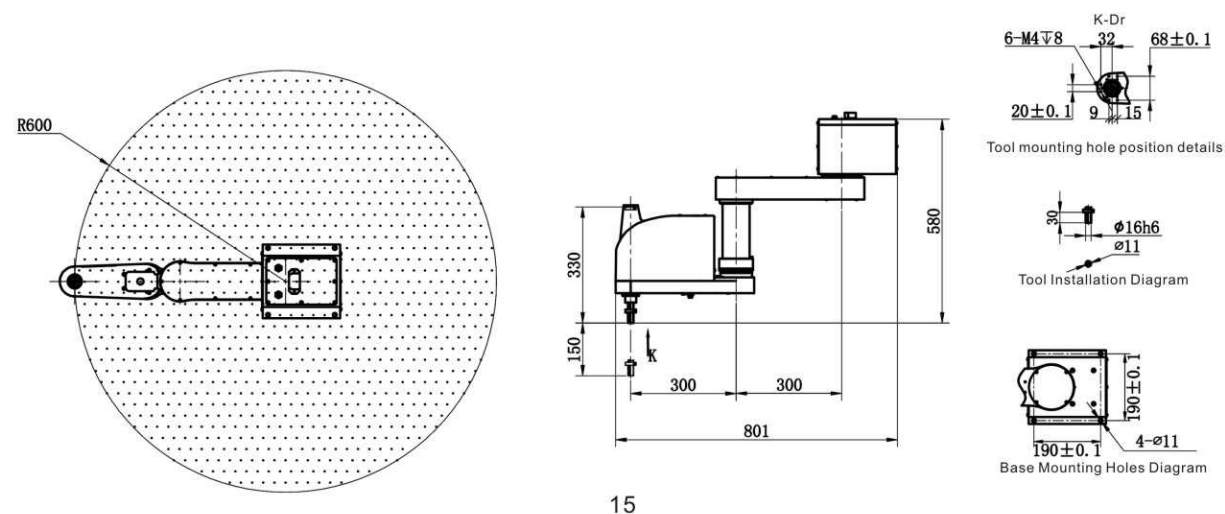

TR SERIES - three axis SCARA robot

TR3208

■ Specification Table

Species			SCARA
Axis specification	X axis	Arm length	100mm
		Rotation range	±127°
	Y axis	Arm length	200mm
		Rotation range	±142°
Z axis	Route	80mm	
Highest speed	X axis		600°/s
	Y axis		375°/s
	X, Y-axis synthesis		4.45m/s
	Z axis		0.83m/s
Repeat positioning accuracy	X, Y-axis		±0.01mm
	Z axis		±0.01mm
User signal line			1. Software limit 2. Mechanical limit (X, Y, Z axis)
Users pipe			0.2sq × 16 lines, 8 output, 6 input
Limit protection			Φ6×2 root
Weight			11.5kg



Standard cycle time (rated load)

0.45s

Arm length (mm)

300

Rated / max load

2kg/5kg

System

QC400A

■ Robot Movement Space, Shape and Installation Dimension (Unit: mm)

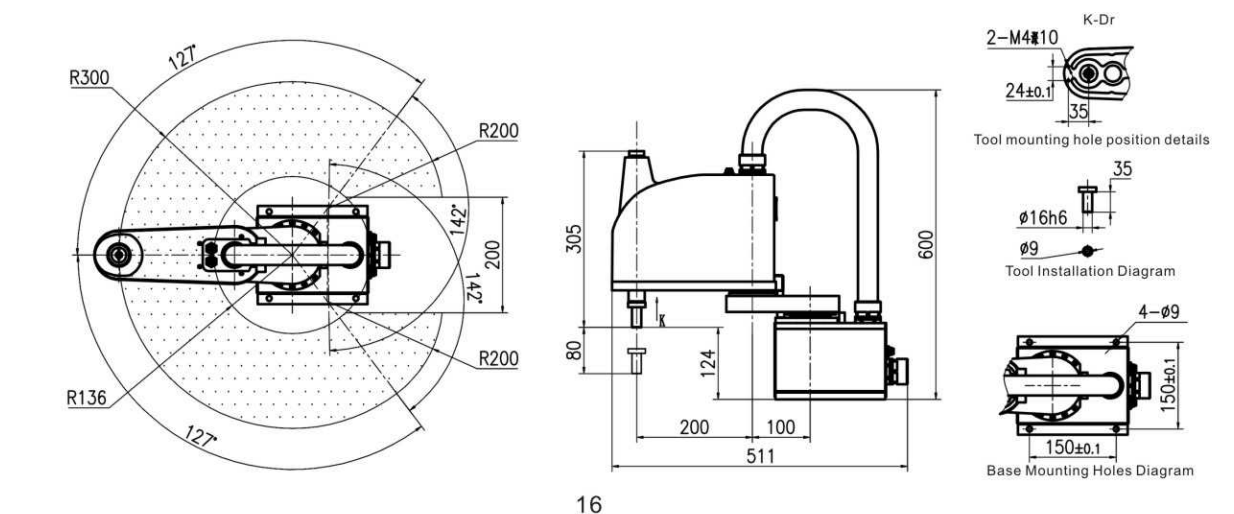

TR SERIES - three axis SCARA robot

TR4208

■ Specification Table

Species		SCARA	
Axis specification	X axis	Arm length	200mm
		Rotation range	±127°
	Y axis	Arm length	200mm
		Rotation range	±142°
Z axis	Route	80mm	
Highest speed	X axis		600°/s
	Y axis		375°/s
	X, Y-axis synthesis		5.5m/s
	Z axis		0.83m/s
Repeat positioning accuracy	X, Y-axis		±0.01mm
	Z axis		±0.01mm
User signal line		1. Software limit 2. Mechanical limit (X, Y, Z axis)	
Users pipe		0.2sq × 16 lines, 8 output, 6 input	
Limit protection		Φ6×2 root	
Weight		11.8kg	



Standard cycle time(rated load)

0.4s

Arm length (mm)

400

Rated / max load

2kg/5kg

System

QC400A

■ Robot Movement Space, Shape and Installation Dimension (Unit: mm)

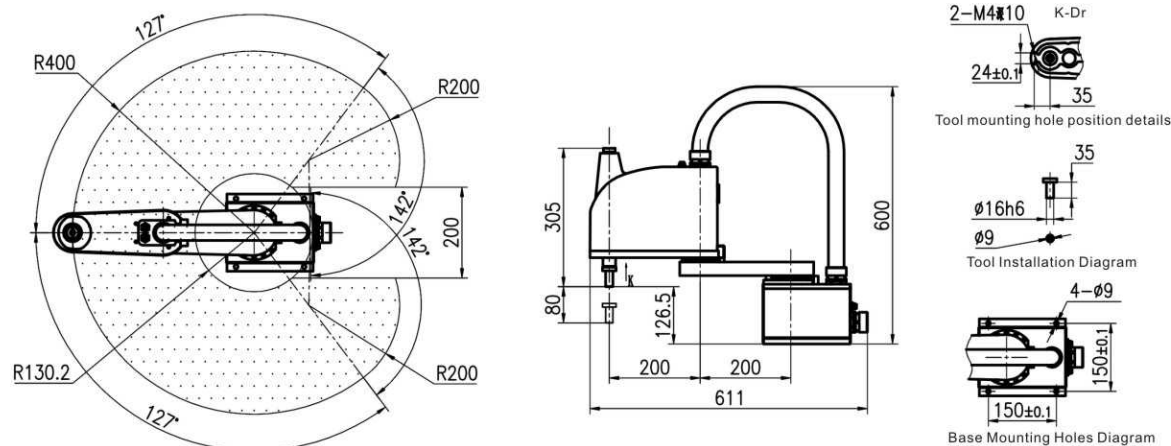

TR SERIES - three axis SCARA robot

TR5208

■ Specification Table

Species		SCARA	
Axis specification	X axis	Arm length	300mm
		Rotation range	±127°
	Y axis	Arm length	200mm
		Rotation range	±142°
Z axis	Route	80mm	
Highest speed	X axis		600°/s
	Y axis		375°/s
	X, Y-axis synthesis		6.5m/s
	Z axis		0.83m/s
Repeat positioning accuracy	X, Y-axis		±0.01mm
	Z axis		±0.01mm
User signal line		1. Software limit 2. Mechanical limit (X, Y, Z axis)	
Users pipe		0.2sq × 16 lines, 8 output, 6 input	
Limit protection		Φ6×2 root	
Weight		12.1kg	



Standard cycle time(rated load)

0.45s

Arm length (mm)

500

Rated / max load

2kg/5kg

System

QC400A

■ Robot Movement Space, Shape and Installation Dimension (Unit: mm)

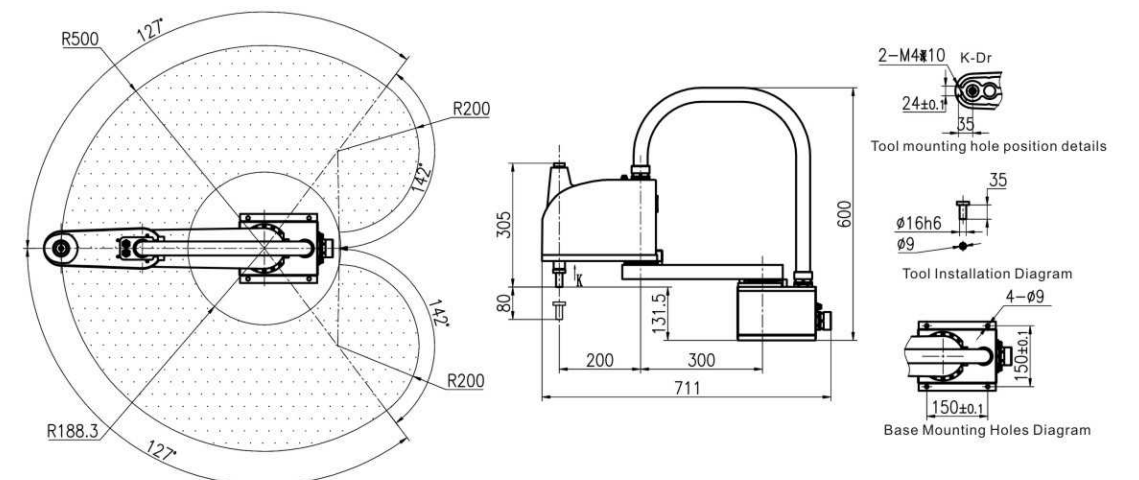

SA1400 Welding Robot

SA 1400

Product Introduction

SA Series robots are compact, small and lightweight, ideal for welding application due to its high stability. It can realize high welding-path accuracy, considerably reduce welding cycle-time, and extend the lifetime of tubes and cables. In addition, SA Series robots can fit in narrow working space and can be floor mounted, inverted or tilted in any angle.

Main Applications

- ▲ Arc welding
- ▲ Material handling
- ▲ Cutting
- ▲ Palletizing

Working Space

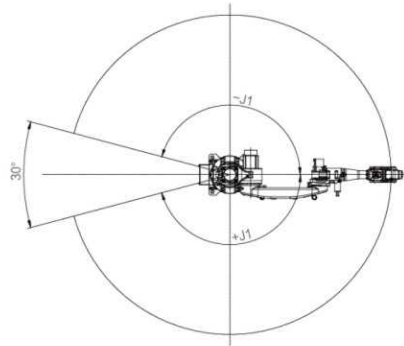
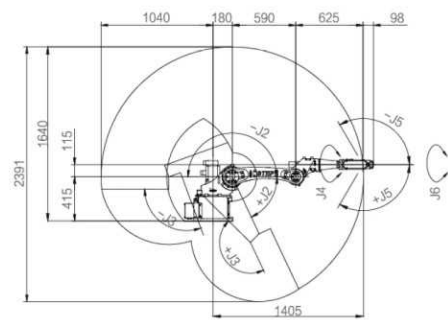

Technical Specifications

Model	SA 1400	
Wrist Payload	6 kg	
Max Working Radius	1405 mm	
DOF	6	
Max Speed	J1	150° /s
	J2	150° /s
	J3	160° /s
	J4	360° /s
	J5	320° /s
	J6	360° /s
Max Operation Area	J1	± 165°
	J2	+65° ~ -180°
	J3	+160° ~ -110°
	J4	± 170°
	J5	± 120°
	J6	± 360°
The Max Moment Allowable Torque	J5	54 Nm
	J6	23 Nm
Weight	143 kg	
Position Repeatability	± 0.05 mm	
Working Temperature	0 ~ 45°C	
IP Protection Level of Robot	IP40	
IP Protection Level of Control Cabinet	IP30	



6-axis robot control system



RX600 SERIES

- EtherCAT · POWERLINK bus-type
- Load range : 5-270 kg

Basic specifications

Electric	Stable input voltage : Three-phase 380VAC 50Hz or 220VAC 50Hz
	Power supply : 20KVA (max)
	Power frequency : 50Hz
	Ambient temperature : 0 - 40°C
Control	Environment humidity : 45 - 80% RH
	Number of axes : maximum expansion of 12
	Advanced multiprocessing control system
	Advanced Robot Editing Language
Safety	Portable, open, and extensible
	Pre-installed software, and supply a CD-ROM
	Emergency safety shutdown
Digital	Two - channel safety circuit with detection
	Three starter
Field-bus	Reserved external security interface
	24 VDC or Relay signal
	EtherCAT
	POWERLINK
	CANopen
	EtherNet/IP

Applications



Spot welding robot + Arc welding robot

Handling robot

Palletizing robot

Stamping and bending robot

AVS series vision position system

Product Introduction

Positioning fast and precision, the system stable and efficient, easy to operate



Function Introduction

- Support Gigabit Ethernet, USB and so on the many kinds of different cameras
- Support array CCD camera
- Short time of system positioning
- Support online or offline inspection
- Support RS232, Ethernet and so on many kind of communication interface
- Consistent with OPC standard

Software specification:

- Positioning algorithm can reach 1/64 pixel, output position, rotation Angle and scaling
- Support for multiple cameras collecting at the same time, and positioning
- Support for different resolutions, different camera interface
- Support import local images, emulates camera collecting function
- Provide tools for edge positioning and area positioning
- Edge positioning, can quickly positioning figure clear object, and can calculate any rotation Angle;
- Regional positioning, suitable for irregular shapes, low contrast object;
- Provide scale calibration, the calibration tool with mapping coordinates, can be converted into real physical pixel units, and to correct lens and perspective distortion.
- Drag and drop software operation, intuitive and efficient, to quickly build a set of visual positioning system.
- Supports Ethernet, serial communication mode for file reading and writing, you can quickly locate the results output to the external control of system or file system
- Support the new process, save, and read, and can save to local file, apply directly when loaded again without setting

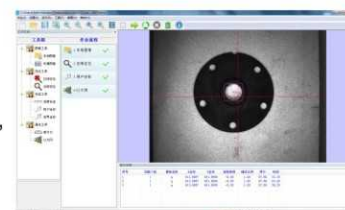

Vision System Components:

Vision controller + Industrial Camera + Lens + Light source + Controller of light source + CCD Data cable + USB encryption dog

Product Configuration:

System Type	Name	Model	Description	Quantity
Single Camera System	Vision controller	AVS1100	Industrial PC + Smart card +Vision software	1
	Industrial camera	300 thousand, 2 million, 5 million pixel can be selected, refer 《Vision system selection table》		1
	Lens	Refer 《Lens selection table》		1
	Light source	Refer 《Light source selection table》		1
	Controller of light source	Refer 《Controller of light source selection table》		1
	CCD Data Cable	3M,5M,7M can be selected, refer 《Vision system selection table》		1
	Encryption dog	USB Encryption dog, Blue Label of Laser printing.		1
Double Camera System	Vision controller	AVS3100	Industrial PC + Smart card +Vision software	1
	Industrial camera	300 thousand, 2 million, 5 million pixel can be selected, refer 《Vision system selection table》		2
	Lens	Refer 《Lens selection table》		2
	Light source	Refer 《Light source selection table》		2
	Controller of light source	Refer 《Controller of light source selection table》		1
	CCD Data Cable	3M,5M,7M can be selected, refer 《Vision system selection table》		2
	Encryption dog	USB Encryption dog, Blue Label of Laser printing.		1

Applications:



Robot industrial of pick and place and palletizing

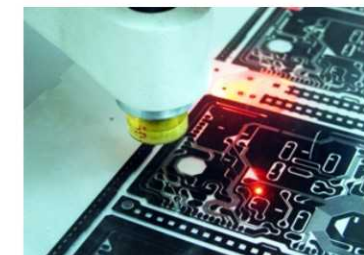

PCBA electronic Industrial



LED Industrial



Dispensing Industrial



Cutting Industrial